



O C P A

**Ontario
Concrete Pipe
Association**

**Concrete
Pipe
Installation**

Pocket Guide

September 2010

**This booklet is simply a guide and is
not intended to supersede the
project specifications.**



**447 Frederick Street, Suite 200
Kitchener, ON N2H 2P4**

1-800-435-0116

www.ocpa.com

Contents

| | |
|--|-----------|
| OCPA PRODUCER MEMBERS | 1 |
| INTRODUCTION | 3 |
| ONTARIO PROVINCIAL STANDARDS | 4 |
| ONTARIO BUILDING CODE | 5 |
| PLANT PREQUALIFICATION PROGRAM | 6 |
| CONCRETE PIPE PARTS | 7 |
| Wall Thickness:..... | 8 |
| PRE-CONSTRUCTION | 9 |
| Site Preparation..... | 11 |
| Clearing and grubbing | 11 |
| Ordering and Receiving | 12 |
| Product Inspection | 13 |
| UNLOADING, STOCKPILING AND STORAGE..... | 14 |
| Unloading..... | 15 |
| 900 mm Diameter and Smaller | 15 |
| 975 mm Diameter and Larger | 16 |
| Stockpiling..... | 17 |
| Storage..... | 18 |
| SOIL TYPES..... | 20 |
| PIPE INSTALLATION | 22 |
| Line and Grade | 22 |
| Equipment..... | 26 |
| Excavation..... | 26 |
| Excavated Material..... | 27 |
| Dewatering..... | 28 |
| Excavation Limits | 29 |
| Sheathing and Shoring | 31 |

| | |
|--|-----------|
| Open Sheathing..... | 33 |
| Close Sheathing..... | 33 |
| Tight Sheathing | 33 |
| Trench Boxes..... | 33 |
| Foundation Preparation..... | 34 |
| Pipe Bedding | 36 |
| Bedding Materials | 38 |
| Class B Bedding | 38 |
| Class C Bedding | 39 |
| Cover..... | 40 |
| Backfill | 41 |
| Handling..... | 43 |
| Load-Carrying Capacity of Lift Anchors..... | 44 |
| Handling Pipe | 44 |
| How to Use Lift Anchors for Setting Pipe..... | 45 |
| Jointing | 47 |
| Jointing Materials | 47 |
| Rubber Compound | 48 |
| Mastic..... | 49 |
| Mortar | 49 |
| External Bands..... | 50 |
| Jointing Procedures | 51 |
| Summary of Jointing Procedures for Pre- lubricated Gasket for Single Offset Joints..... | 53 |
| Summary of Jointing Procedures for O-Ring Gasket..... | 55 |
| Service Connections | 59 |
| Changes in Alignment | 59 |
| MH INSTALLATION | 61 |
| Prebenched MH Monobases..... | 61 |

| | |
|--|-----------|
| Handling MH Sections..... | 62 |
| MH Connections..... | 64 |
| Precast Concrete Adjustment Units..... | 65 |
| Frames with Grates or Covers | 66 |
| BOX UNIT INSTALLATION..... | 67 |
| FIELD TESTING | 68 |
| Soil Density..... | 68 |
| Visual/Video Inspection | 69 |
| Infiltration Testing | 70 |
| Exfiltration Testing..... | 71 |
| Testing With Water | 72 |
| Low Pressure Air Testing | 73 |
| Leakage Test Acceptance | 74 |
| APPENDIX..... | 76 |
| Jacking Method of Installation | 78 |
| Damage Assessment..... | 82 |
| Joint Integrity..... | 83 |
| Cracks | 85 |
| Basis of Acceptance..... | 90 |
| Autogenous Healing | 92 |
| Rehabilitation Techniques..... | 93 |
| Chemical Grout | 94 |
| Trenchless Technologies..... | 95 |
| REFERENCES | 97 |

OCPA PRODUCER MEMBERS



1-800-668-7473

Guelph

299 Brock Road South
Tel: (519) 763-8655

Oakville

641 Burloak Drive
Tel: (905) 825-2691



1-888-888-3222

Cambridge

2099 Roseville Road
Tel: (519) 622-7574

Ottawa

3374 Rideau Road
Tel: (613) 822-0160

Whitby

1818 Hopkins Street South
Tel: (905) 668-9441

Windsor

2415 Division Road
Tel: (519) 966-0510



1-866-537-3338

Cambridge

2691 Greenfield Road
Tel: (519) 632-9112

Concrete Pipe Installation



Ottawa

1-800-267-5515

2150 Richardson Side Road

Tel: (613) 831-1736



Barrie

1-800-461-5632

8807 Simcoe Road #56

Tel: (705) 734-2892



Concrete Industries Ltd.

Sudbury

1-800-461-6281

2477 Maley Drive

Tel: (705) 566-1740

INTRODUCTION

The design of a concrete pipeline assumes that certain minimum conditions of installation will be met.

Acceptance criteria are established to ensure that the quality of workmanship and material provided during construction meet the design requirements, and that the pipeline will perform properly.

Installation and field testing are the final steps in a process that also includes research, surface and sub-surface investigations, design, specification preparation, pipe manufacturing, and material testing.

Installation procedures are presented in this guide, together with some of the problems that might be encountered. These procedures include:

- Pre-construction planning
- Site preparation
- Ordering, receiving, unloading, and stockpiling
- Excavation
- Foundation and bedding preparation
- Jointing and connections to MH's
- Backfilling
- Construction field testing
- Damage assessment and rehabilitation

This booklet is simply a guide and is not intended to supersede the project specifications.

ONTARIO PROVINCIAL STANDARDS

The Ontario Provincial Standards for Roads and Public Works (OPS) were published for the first time in January 1984, with the intent of improving the administration and cost-effectiveness of road building and other municipal services, such as sewers and watermains. These standard drawings and specifications correspond to those used by many municipalities and the Ministry of Transportation.

The OPS organization is co-owned by the Municipal Engineers Association (MEA) and the Ministry of Transportation of Ontario (MTO). An online version of the Standards can be found at:

www.ops.on.ca

The Ontario Provincial Standards currently contain the following manuals:

- Ontario Provincial Standards Specifications (OPSS)**
- Ontario Provincial Standards Drawings (OPSD)**

Relevant OPS documents are listed in some sections of this guide for easy reference.

ONTARIO BUILDING CODE

In Ontario, the *Building Code Act*, 1992 (BCA) is the legislative framework governing buildings. The BCA requires that each municipality appoint a chief building official to enforce the Act in the areas in which the municipality has jurisdiction.

The Ontario Building Code (OBC) is a regulation under the BCA and establishes detailed technical and administrative requirements, including Division B, Part 7 for Plumbing and Part 8 for Sewage Systems. For many projects involving a building, the Ontario Building Code will govern instead of the Ontario Provincial Standard, or local municipal standards. In the OBC, “building” means,

- a structure occupying an area greater than ten square metres consisting of a wall, roof and floor or any of them or a structural system serving the function thereof including all plumbing, works, fixtures and service systems appurtenant thereto,
- a structure occupying an area of ten square metres or less that contains plumbing, including the plumbing appurtenant thereto,
- plumbing not located in a structure,
- a sewage system, or
- structures designated in the building code

The Building and Development Branch of the Ministry of Municipal Affairs and Housing administers the Ontario Building Code.

PLANT PREQUALIFICATION PROGRAM

Under the Ontario Provincial Standard Specifications listed below, manufacturers of precast concrete products must possess a current Prequalification Certificate, issued under the Plant Prequalification Program.

OPSS 1820 Circular Concrete Pipe

OPSS 1821 Precast Reinforced Concrete Box Culverts and Box Sewers

OPSS 1351 Precast Reinforced Concrete Components for Maintenance Holes, Catch Basins, Ditch Inlets, and Valve Chambers

Plants that are prequalified must identify all products covered by their certification, with this marking:



CONCRETE PIPE PARTS

Note: Pipe dimensions and product mass may vary slightly by manufacturer.

Cross-Section:

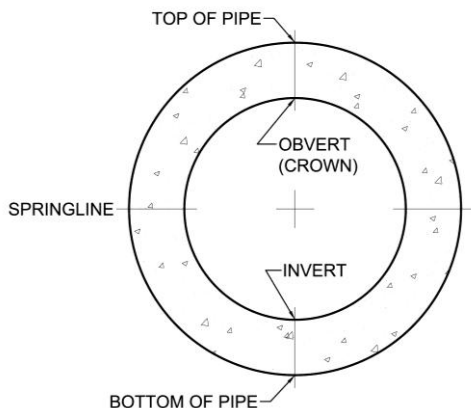

Longitudinal:

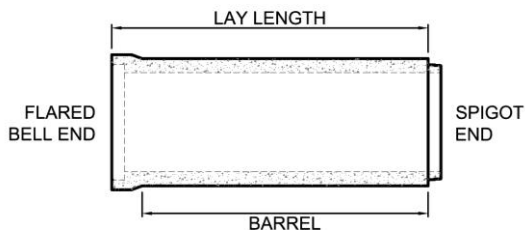

975mm Diameter & Smaller

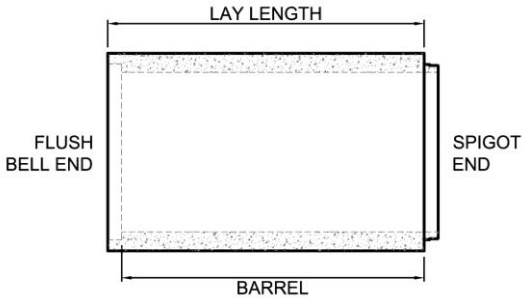

1050mm Diameter & Larger

Wall Thickness:

Concrete pipe is typically supplied with industry standard wall thicknesses, but may vary by manufacturer. The following equations can be used to determine the standard wall thickness, t , in inches:

$$\text{WALL A: } t = \frac{\text{ID}}{12}$$

$$\text{WALL B: } t = \frac{\text{ID}}{12} + 1$$

$$\text{WALL C: } t = \frac{\text{ID}}{12} + 1.75$$

Where: **ID** = inside pipe diameter in inches.

PRE-CONSTRUCTION

Pre-construction planning is essential for a successful project. All plans, project specifications, soils reports, standard drawings, and special provisions must be reviewed prior to construction, and any questioned areas resolved. A review of the plans at the project site is helpful in identifying potential problems. Addressing these potential problems can eliminate unnecessary and costly delays.

All personnel associated with the project should become familiar with codes of safe practice regarding construction for federal, provincial, municipal and local agencies. Federal safety regulations for construction are published in the *Canada Labour Code*. In Ontario, the provincial safety regulations are published in the ***Occupational Health and Safety Act*** and ***Ontario Regulation 213/91 for Construction Projects***.

To avoid delays during construction, information should be obtained on several pre-construction items such as:

- Names and addresses of agencies having jurisdiction over highways, railroads, airports, utilities, drainage, etc.
- Required easements, permits, releases or any other special stipulations.
- Responsibility for notifying officials of existing utilities and, if necessary, requesting appropriate agencies to locate and mark facilities affected.

Concrete Pipe Installation

- ❑ Locate benchmarks, monuments and property stakes, and reference all points likely to be disturbed.
- ❑ Check grade and alignment, clearing requirements, and ensure building connections, watermains, hydrants and other appurtenances are properly staked.
- ❑ Coordinate work to be done, and requirements of subcontractors.
- ❑ Arrange for measurement of pay quantities and procedures for change orders or extra work orders.
- ❑ Safety regulations, equipment capabilities and requirements for traffic maintenance.
- ❑ Establish forms for record keeping, progress reports, diary, etc.

Site Preparation

Site preparation can significantly influence progress of the project. The amount and type of work involved in site preparation varies with the location of the project, topography, surface conditions, and existing utilities. Commonly included are:

- Detours and traffic control signing
- Access roads

Clearing and grubbing

- Tree relocation or protection
- Stripping and stockpiling topsoil
- Pavement and sidewalk removal
- Management of excess material
- Relocation of existing natural drainage
- Notifications and protection of existing structures and all utilities
- Environmental considerations, such as temporary erosion and sediment control.

References in Ontario Provincial Standards:

| | |
|-----------------|--|
| OPSS 503 | Site Preparation for Pipelines, Utilities, and Associated Structures |
| OPSS 504 | Preservation, Protection, and Reconstruction of Existing Facilities |
| OPSS 510 | Removal |
| OPSS 577 | Temporary Erosion & Sediment Control Measures |

Ordering and Receiving

Although the ordering of materials is the contractor's responsibility, supplier and design engineer familiarity with the contractor's proposed schedule will enable better coordination to avoid mistakes and possible delays in pipe deliveries. Pipe manufacturers stock a wide range of pipe sizes and strength classes, however production schedules must frequently be adapted to meet specific project requirements, particularly when large quantities and/or special types of pipe are involved that require longer lead times for delivery. Information required to initiate a pipe order should be in writing and include:

- Name and location of project
- Pipe size, type and strength class
- Total length of each size and type of pipe
- Joint material and quantity
- List of special fittings
- Installation sequence
- Size and details of MH and CB structures
- Material test requirements
- Invoicing instructions

The delivery of pipe should be coordinated with the construction schedule and installation sequence to avoid re-handling and unnecessary equipment movement. Access to the jobsite should be provided by the contractor to ensure that the pipe manufacturer's trucks can deliver pipe to the unloading area under their own power.

Product Inspection

Each shipment of concrete pipe is loaded, blocked and tied down at the plant to avoid damage during transit. The pipe should be inspected on the truck when it first arrives at the jobsite before it is unloaded to ensure that no damage has occurred during transit. Damaged or missing items must be reported at this time.

It is important to check that the pipe is the correct size and strength class, and that it is supplied with the proper gasket. The pipe should be checked for the following information, clearly marked on each pipe section:

- specification designation
- pipe class or strength designation
- date of manufacture
- name or trademark of the manufacturer
- plant identification
- product certification, such as the PPP stamp



- for pipe with elliptical reinforcement or otherwise requiring special placement, appropriate marking to indicate clearly the correct pipe orientation when installed
- the marking of jacking pipe with a “J”
- other markings as specified by the owner

Unloading, Stockpiling and Storage

IMPORTANT

The work procedures for material handling, worker safety, the modification of backhoes for use as cranes, and all components of any lifting assembly must comply with the Occupational Health and Safety Act requirements for Construction Projects (Ontario Regulation 213/91). A competent person designated by the contractor should inspect all lifting assemblies and attachment hardware prior to each use. Any damage or defective equipment must be immediately removed from service. All other safety procedures and recommended operating practices by the manufacturer of the lifting equipment must be followed. Failure to observe the above warnings may lead to property damage, personnel injury and death.

If a pipe is damaged during delivery or unloading, the pipe should be set aside. Damaged ends, chips or cracks which do not pass through the pipe wall can usually be repaired. The pipe manufacturer can provide advice on proper repair methods.

If the pipe has to be moved after unloading, the sections should be rolled or lifted, and should never be dragged. Pipe sections should not be rolled over rough or rocky ground.

Unloading

Unloading of the pipe should be done on a level site and be controlled to avoid colliding with other pipe sections. Care should be taken to avoid damage, especially to the spigots and bells. Caution should be exercised to ensure personnel are out of the path of the pipe as it is moved.

900 mm Diameter and Smaller

Lifting devices such as slings, chains or cables should be placed around the pipe, or arranged so that the pipe is lifted in a horizontal position at all times. If the lifting device could chip or damage the pipe, padding should be provided between the pipe and lifting device. These types of lifting devices should not be passed through the pipe.

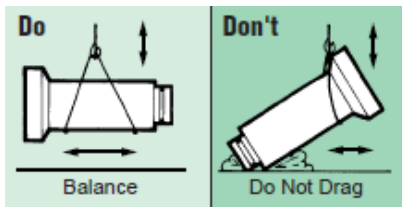

A common device used for unloading small to intermediate diameter pipe (900 mm and smaller), is a lift fork. Lift forks are easily attached to the mechanical equipment on-site, usually a front end loader. Lift forks make unloading more efficient, and enable the contractor to easily move pipe around the site.

Concrete Pipe Installation

Since the incorporation of palletizing small diameter pipe (up to and including 250 mm diameter), lift forks have become necessary to unload the pallets.

975 mm Diameter and Larger

Pipe 975 mm and larger, and maintenance hole sections are typically provided with embedded lift anchors. These lift anchors are designed as part of a complete lifting system, therefore it is imperative that all lifting system components and rigging hardware be used as they are intended. It is also the contractor's responsibility to follow the maintenance and inspection routine recommended by the lifting system manufacturer.

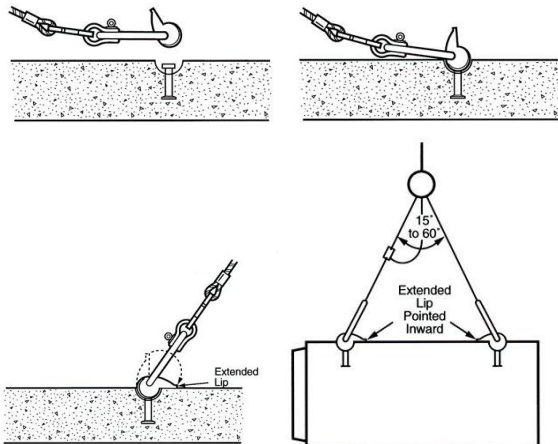

When pipe is provided with lift holes, the lifting device should pass through the wall and distribute the weight

along the inside barrel of pipe. Concrete pipe with lift holes, require a specially designed lifting device consisting of a steel thread eye bar with a wing type nut and bearing plate. For maintenance hole sections, fittings and other precast appurtenances with lift holes, properly designed and sized lifting pins should be used.

Stockpiling

For trench installations, where the trench is open, the pipe should be placed on the side opposite the excavated material. The pipe sections should be placed so that they are protected from traffic and construction equipment, but close enough to the trench edge to minimize handling.

If the trench is not yet open, the pipe should be strung out on the opposite side from where the excavated material will be placed. Stringing out the pipe for embankment installations depends on the specific type of installation. To avoid disruption to existing natural drainage and enable embankment construction to proceed as quickly as possible, pipe installation should follow immediately after preparation of the bedding foundation.

For culverts to be installed on shallow bedding at approximately the same elevation as original ground, the pipe should be strung out immediately after clearing and rough grading.

When pipe is installed in a sub-trench or negative projecting condition, the embankment should be

constructed up to the required elevation, and the same procedure followed as for trench installations.

Storage

Storage of pipe should be as close as is safely possible to where the pipe will be installed. Pipe sections generally should not be stored at the job site in a greater number of layers that would result in a height of 2 m.

Pipe should be layered in the same manner as they were loaded on the truck. Pipe should be placed on timbers to prevent them from becoming frozen to the ground in the winter, and to permit ease of handling in summer. For small diameter pipe sizes that have protruding bells, the pipe barrel should carry the weight of the pipe keeping the bell ends free of load concentrations.

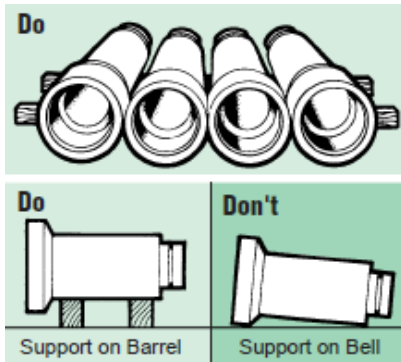

The bottom layer should be placed on a level base, on timbers supporting the barrel at either end. Each layer of

bell and spigot pipe should be arranged so that bells are at the same end. The bells in the next layer should be at the opposite end, and projecting beyond the spigot of the section in the lower layer. Where only one layer is being stockpiled, the bell and spigot ends should alternate between adjacent pipe sections.

All flexible gasket materials, including joint lubricating compounds where applicable should be stored in a cool dry place in the summer, and prevented from freezing in the winter. Rubber gaskets and preformed mastics should be kept clean, away from oil, grease, excessive heat, and out of direct sunlight.

SOIL TYPES

The type of soil in which an excavation is made should be determined by visual and physical examination of the soil at the walls of the excavation; and within a horizontal distance from each wall equal to the depth of the excavation measured away from the excavation.

The soil type in which an excavation is made should be classified as defined in *the OHSA Ontario Regulation 213/91 - Construction Projects*, which are listed below. **If an excavation contains more than one type of soil, the soil should be classified as the type with the highest number.**

| | |
|----------------|--|
| Type 1: | <input type="checkbox"/> is hard, very dense and only able to be penetrated with difficulty by a small sharp object; |
| | <input type="checkbox"/> has a low natural moisture content and a high degree of internal strength; |
| | <input type="checkbox"/> has no signs of water seepage; and |
| | <input type="checkbox"/> can be excavated only by mechanical equipment. |

| | |
|----------------|---|
| Type 2: | <input type="checkbox"/> is very stiff, dense and can be penetrated with moderate difficulty by a small sharp object; |
| | <input type="checkbox"/> has a low to medium natural moisture content and a medium degree of internal strength; and |
| | <input type="checkbox"/> has a damp appearance after it is excavated. |

- Type 3:**
- is stiff to firm and compact to loose in consistency or is previously-excavated soil;
 - exhibits signs of surface cracking;
 - exhibits signs of water seepage;
 - if it is dry, may run easily into a well-defined conical pile; and
 - has a low degree of internal strength.

- Type 4:**
- is soft to very soft and very loose in consistency, very sensitive and upon disturbance is significantly reduced in natural strength;
 - runs easily or flows, unless it is completely supported before excavating procedures;
 - has almost no internal strength;
 - is wet or muddy; and
 - exerts substantial fluid pressure. In relation to a wall of an excavation, means the lateral pressure of the earth on the wall calculated in accordance with generally accepted engineering principles and includes hydrostatic pressure and pressure due to surcharge on its supporting system.

PIPE INSTALLATION

References in Ontario Provincial Standards:

OPSS 410 Pipe Sewer Installation In Open Cut

OPSS 421 Pipe Culvert Installation In Open Cut

Line and Grade

For sewer construction, where the pipe is installed in a trench, line and grade are usually established by one, or a combination of the following methods:

- Control points consisting of stakes and spikes set at the ground surface, and offset a certain distance from the proposed sewer centerline
- Control points established at the trench bottom, after the trench is excavated
- Trench bottom and pipe invert elevations established while excavation and pipe installation progresses
- Global Positioning System (GPS)

IMPORTANT

Line and grade should be checked as the pipe is installed, and any discrepancies between the design and actual alignment and pipe invert elevations should be corrected prior to placing the backfill or fill over the pipe.

Obtaining manhole invert levels for the preparation of as-built drawings, combined with visual inspection of the sewer or culvert, provide an additional check that

settlement has not occurred during backfill or fill operations.

Where control points are established at the surface and offset, lasers, transits, batter boards, tape and level, or specially designed transfer instruments, are used to transfer line and grade to the trench bottom. Regardless of the specific type of transfer apparatus used, the basic steps are:

- ❑ Stakes and spikes, as control points, are driven flush with the ground surface at 7.5 to 15m intervals for straight alignment, with shorter intervals for curved alignment.
- ❑ Offset the control points 3m, or another convenient distance, on the opposite side of the trench from which excavated material will be placed.
- ❑ Determine control point elevations by means of a level, transit or other leveling device. Drive a guard stake to the control point, and mark the depth of the control point from the control point to the trench bottom or pipe invert.
- ❑ After the surface control points are set, a grade sheet is prepared listing reference points, stationing, offset distance and vertical distance from the control points to the trench bottom or pipe invert.

Transferring the line and grade along the trench bottom is achieved by using a laser system, or a batter board system.

The laser system, the most commonly used system, uses a transit or level to set the starting point on the trench bottom. As with any surveying instrument, the initial setting is most important. Once the starting point is established, the laser can be set for direction and grade. Lasers can be used for distances up to 300 m (average runs for pipe installations are 90 to 150 m). The projected beam is intercepted along the trench bottom with a target, placed in the bell that accepts the light.

Temperature can affect the trueness of the laser beam; therefore, it is helpful to keep the line well ventilated. The laser instrument can be mounted in a maintenance hole, set on a tripod or placed on a solid surface to project the light beam either inside, or outside the pipe. A workman with any ordinary rule, or stadia rod, can measure offsets quickly and accurately, generally within 2 mm or less.

There are two types of batter board systems. One type is incorporated for narrow trenches, the other for wide trenches.

For narrow trenches, a horizontal batter board is spanned across the trench, and adequately supported at each end. The batter board is set level at the same elevation as the stringline, and a nail driven in the upper edge, at the centre line of the pipe. In many cases the batter board is used only as a spanning member, with a short vertical board nailed to it at the pipe centerline. A stringline is pulled tight across a minimum of three batter boards, and the line transferred to the bottom by a plumb bob cord

Concrete Pipe Installation

held against the stringline. Grade is transferred to the trench bottom by means of a grade rod, or other suitable vertical measuring device.

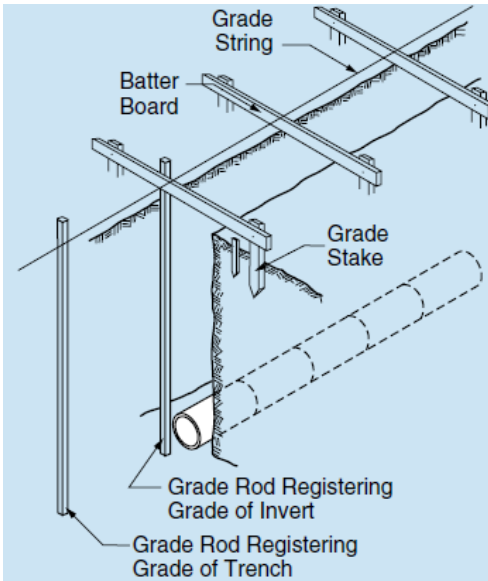

Example Batter Board Set-up for Narrow Trench

Where wide trenches are necessary, due to large pipe sizes or sloped trench walls, the batter board may not be able to span the width of excavation. In such cases, the same transfer principle is used, except that the vertical grade rod is attached to one end of the batter board, and the other end set level against the offset stringline. The length of horizontal batter board is the same as the offset distance. The length of the vertical grade rod is the same as the distance between the pipe invert and the stringline.

Specially designed instruments are available which incorporate a measuring tape, extendible arm and leveling device. These instruments are based on the same principle, but eliminate the need to construct batter boards and supports.

Equipment

Several types of excavating equipment are available. Selection of the most efficient piece of equipment for a specific excavation operation is important, since all excavating equipment has practical and economic limitations. Considerations include the type and amount of material to be excavated, depth and width of excavation, dimensional limitations established in the plans, pipe size, operating space and spoil placements. Basic equipment can usually be modified or adapted for use in most excavating operations.

Excavation

For sewer and culvert construction, the scope of operations involved in general excavation includes trenching, tunneling, backfilling, embankment construction, soil stabilization, and control of ground water and surface drainage. Adequate knowledge of subsurface conditions is essential for any type of excavation.

This is accomplished through soil surveys and subsequent soil classification. Soil borings are usually obtained for design purposes, and the information included on the

plans, or made available to the contractor in a separate document. This soil boring information is useful in evaluating unsuitable subsoil conditions requiring special construction. If the subsoil information on the plans is not sufficiently extensive, it is normally the responsibility of the contractor to obtain additional test borings.

References in Ontario Provincial Standards:

| | |
|-----------------|---|
| OPSS 514 | Trenching, Backfilling, and Compacting |
| OPSS 515 | Rock Excavation for Pipelines, Utilities, and Associated Structures in Open Cut |

Excavated Material

The placement of excavated material is an important consideration in sewer and culvert construction, and may influence the selection of excavating equipment, the need of providing sheathing and shoring, and backfill operations.

In trench installations, the excavated material is usually used for backfill, and should be placed in a manner that reduces re-handling during backfilling operations. As a general rule, for unsupported trenches, the minimum distance from the trench to the toe of the spoil bank should not be less than one half the trench depth. For supported trenches, a minimum of one metre is normally sufficient.

Stockpiling excavated material adjacent to the trench causes a surcharge load, which may cave in trench walls.

The ability of the trench walls to stand vertically under this additional load depends on the cohesion characteristics of the particular type of material being excavated. This surcharge load should be considered when evaluating the need to provide trench support. It may be necessary, where deep or wide trenches are being excavated, to haul away a portion of the excavated soil, or spread the stockpile with a bulldozer, or other equipment. If the excavated material is to be used as backfill, the stockpiled material should be visually inspected for rocks, frozen lumps, highly plastic clay, or other objectionable material. If the excavated soil differs significantly from the backfilled material set forth in the plans, it may be necessary to haul the unsuitable soil away and bring in selected backfill material.

Spoil placement for culvert installations is usually not as critical as trench installation. If the excavated material is suitable for the embankment construction, it can be immediately incorporated into the embankment adjacent to the culvert. If using imported materials, care must be taken so that the frost susceptibility is the same as the native material. Top soil, or other highly organic soils, are usually stockpiled outside the top of the embankment slope, and used for dressing the slopes after the embankment is constructed.

Dewatering

Dewatering of trenches and excavations should be undertaken in order to keep the excavation stable and free of water. Dewatering efforts must be monitored for

impacts such items as settlement and ground water usage. When dewatering efforts are no longer required they must be arrested such that no disturbance to the pipe will occur.

Water from dewatering operations must be disposed of in accordance with local regulations. Pumped water requires that it be filtered through a sediment control device and disposed of such that it does not impact public health or safety, property or the environment. Water should not be directed over pavements or sidewalks or effect the functionality of settling ponds and sediment basins.

References in Ontario Provincial Standards:

- OPSS 517** Dewatering of Pipeline, Utility, and Associated Structure Excavation
- OPSS 518** Control of Water from Dewatering Operations

Excavation Limits

It is the contractor's responsibility to adhere to all Occupational Health and Safety Act requirements for excavations. The sloping requirements for Soil Type 1, 2, 3 or 4 is described in OHSA Ontario Regulation 213/91 for Construction Projects and is detailed in the OPSS 802.03X series drawings.

OPSS 514 requires that no more than 15 m of trench be open in advance of the completed pipe system.

The most important excavation limitations are trench width and depth. As excavation progresses, trench grades

should be periodically checked against the elevations established on the sewer profile.

Improper trench depths can result in high or low spots in the line, which may adversely affect the hydraulic capacity of the sewer, and require correction, or additional maintenance, after the line is completed. If the trench depth is excavated beyond the limits of the required excavation, granular material should be placed and compacted in the trench to reinstate the required trench limits prior to backfilling the trench.

The backfill load transmitted to the pipe is directly dependent on the trench width at the crown of the pipe. To determine the backfill load, the designer assumes a certain trench width, and then selects a pipe strength capable of withstanding this load. If the constructed trench width exceeds the maximum trench width specified in the design, the pipe may be overloaded and may require the use of a stronger pipe or a higher class of bedding, or both. Where maximum trench widths are not indicated in any of the construction contract documents, trench widths should be as narrow as possible, with side clearance adequate enough to ensure proper compaction of backfill material at the sides of the pipe.

When unstable soil conditions are encountered, sheathing or shoring can be used, or the banks of the trench can be sloped to the natural angle of repose of the native soil. If the trench sides are allowed to slope back, the pipe should be installed in a shallow subtrench excavated at the

bottom of the wider trench. The depth of the subtrench should be at least equal to the vertical height of the pipe.

For a confined trench installation, OPSD 802.03X specifies the following trench widths at the top of the pipe:

| CLEARANCE TABLE | |
|--------------------------------------|---------------------------|
| Pipe Inside Diameter (mm) | Clearance (mm) |
| 900 or less | 300 |
| Over 900 | 500 |

For culverts installed under embankments, it may be possible to simulate a narrow subtrench by installing the pipe in the existing stream bed. When culverts are installed in a negative projecting condition of construction, the same excavation limitations should be followed as for trench excavation.

References in Ontario Provincial Standards:

OPSS 514 Trenching, Backfilling, and Compacting

Sheathing and Shoring

Trench stabilization is usually accomplished through the use of sheathing and shoring. The Occupational Health and Safety Act, Ontario Provincial Standards, and other local agencies have established codes of safe practices regarding support requirements for trench excavations. The structural requirements of sheathing and shoring depend on numerous factors such as:

Concrete Pipe Installation

- depth and width of excavation
- characteristics of the soil
- water content of the soil
- weather conditions
- proximity to other structures
- vibration from construction equipment or traffic
- soil placement or other surcharge loads
- code requirements

Accurate evaluation of all of these factors is usually not possible, so the design and application of temporary bracing systems varies considerably. However, certain methods of stabilizing open trenches have evolved and can be used as a general guide.

Shoring for trenches is accomplished by bracing one bank against the other; structural members which transfer the load between the trench sides are termed struts. Wood planks placed against the trench walls to resist earth pressure, and retain the vertical banks, are termed sheathing. The horizontal members of the bracing system, that form the framework bearing against the sheathing, are termed walers or stringers, and the vertical members of the bracing system are termed strongbacks.

Improper removal of sheathing can reduce the frictional effects, and increase the backfill load on the pipe, so sheathing should be removed in increments, as the backfill is placed. Additional compaction of the backfill material may be necessary to fill the voids behind the sheathing, as it is removed. The four common sheathing methods are:

- open sheathing
- close sheathing
- tight sheathing
- trench shields or boxes

Open Sheathing

Open sheathing consists of a continuous frame, with vertical sheathing planks placed at intervals along the open trench. This method of sheathing is used for cohesive stable soils, where groundwater is not a problem.

Close Sheathing

Close sheathing consists of a continuous frame, with vertical sheathing planks placed side by side to form a continuous retaining wall. This method of sheathing is used for non-cohesive and unstable soils.

Tight Sheathing

Tight sheathing is similar to closed sheathing, except the vertical sheathing planks are interlocked. This method of sheathing is used for saturated soils. Steel sheet piling is sometimes used instead of wood planking.

Trench Boxes

Trench boxes, or shields, are heavily braced boxes of steel, or wood, which can be moved along the trench bottom as excavation and pipe laying progress. Trench boxes are used to protect workers installing pipe in stable ground conditions, where the trenches are deep and not sheathed. Trench shields are also used in lieu of other methods of shoring and sheathing for shallow excavations,

where the sides of the shields can extend from the trench bottom to ground surface. When trench shields are used, care should be taken when the shield is moved ahead, so as not to disturb the bedding or pull the pipe apart.

References in Ontario Provincial Standards:

- OPSS 538** Support Systems
OPSS 539 Temporary Protection Systems

Foundation Preparation

A stable and uniform foundation is necessary for satisfactory performance of any pipe. The foundation must have sufficient load bearing capacity to maintain the pipe in proper alignment and sustain the mass of the backfill, or fill material placed over the pipe. The trench bottom foundation should be checked for hard or soft spots, due to rocks or low load-bearing soils. Where undesirable foundations exist, it should be stabilized by ballasting, or soil modification.

Ballasting requires removal of the undesirable foundation material and replacing it with select materials such as sand, gravel, crushed rock, slag, or suitable earth backfill. The depth, gradation, and size of the ballast depend on the specific material used and the amount of stabilization required, but usually the ballast should be well graded.

Soil modification involves the addition of select material to the native soil. Crushed rock, gravel, sand, slag, or other durable inert materials with a maximum size of 75 mm, is

Concrete Pipe Installation

worked into the subsoil to the extent necessary to accomplish the required stabilization.

In rock, shale or other hard, unyielding soils, the excavation should be continued below grade, and the over-excavation replaced with select material to provide a cushion for the pipe.

References in Ontario Provincial Standards:

OPSS 514 Trenching, Backfilling, and Compacting

Pipe Bedding

Once a stable and uniform foundation is provided, it is necessary to prepare a bedding in accordance with the bedding requirements set forth in the plans, specifications or standard drawings.

An important function of the bedding is to level out any irregularities in the foundation, and assure uniform support along the barrel of each pipe section. The bedding is also constructed to distribute the load bearing reaction, due to the mass of the backfill or fill material, around the lower periphery of the pipe. The structural capacity of the pipe is directly related to this load distribution, and several types of bedding have been established to enable the specification of pipe strengths during the design phase. The following general requirements should be followed:

- ❑ When bell and spigot pipe is to be laid, recesses should be shaped to receive the bells.
- ❑ Bedding material placed in the haunches must be compacted prior to continued placement of cover material.
- ❑ Bedding requiring compacting should be placed in layers not exceeding 200 mm in thickness, loose measurement, and compacted to 95% of the max. density before a subsequent layer is placed.
- ❑ Bedding on each side of the pipe should be completed simultaneously. At no time should the levels on each side differ by more than the 200 mm uncompacted layer.

Concrete Pipe Installation

For trench installations, where space is limited, tamping or pneumatic and mechanical impact tampers kneading action, are primarily useful for soils containing clays. Granular soils are most effectively consolidated by vibration. Compaction equipment can generate significant dynamic forces capable of damaging installed pipe.

Bell holes should be excavated to accommodate projecting joints, and to provide support along the barrel of the pipe.

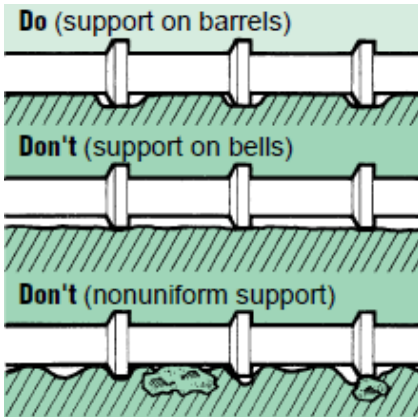

This guide describes the **Class B** and **Class C** bedding types since these are the only types used in the Ontario Provincial Standards for rigid pipe. Other bedding types, such as Standard Installations, are described in the *OCPA Concrete Pipe Design Manual* and the *Canadian Highway Bridge Design Code (CSA S6)*.

Bedding Materials

Materials for bedding should be selected on the basis that uniform contact can be obtained between the bed and the pipe. Since most granular material will shift to attain this uniform contact as the pipe settles, an ideal load distribution can be realized.

OPSS 514 specifies that bedding material be Granular A or B, Type I, II, or III, 25 mm or less in size, or unshrinkable fill, as specified in the Contract documents.

Class B Bedding

Granular Foundation:

- A granular foundation without shaping is used only with circular pipe.
- The pipe is bedded in compacted granular material placed on the flat trench bottom.
- The granular bedding has a minimum specified thickness, and should extend at least half way up the pipe at the sides.
- The remainder of the sidefills, and a minimum depth of 300 mm over the top of the pipe, should be filled with densely compacted material.

Shaped Subgrade:

- For a shaped subgrade with granular foundation, the bottom of the excavation is shaped to conform to the pipe surface but at least 50 mm greater than the outside dimensions of the pipe.

- ❑ The width should be sufficient to allow 0.6 times the outside pipe diameter for circular pipe, 0.7 times the outside span for arch and elliptical pipe, and the full bottom width of box sections to be bedded in fine granular fill placed in the shaped excavation.
- ❑ Densely compacted backfill should be placed at the sides of the pipe to a depth of at least 300 mm above the top of the pipe.

Class C Bedding

Granular Foundation:

- ❑ Used only with circular pipe, the pipe is bedded in loosely compacted granular material, or densely compacted backfill placed on a flat bottom trench.
- ❑ The bedding material should have a minimum specified thickness, and should extend up the sides for a height of at least 0.15 times the outside diameter.
- ❑ For trench installations, the sidefill and area over the pipe to a minimum depth of 150 mm should be filled with compacted backfill.

Shaped Subgrade:

- ❑ The pipe is bedded with ordinary care in a soil foundation, shaped to fit the lower part of the pipe exterior with reasonable closeness for a width of at least 0.5 times the outside diameter for a circular pipe, 0.15 times the outside pipe rise for elliptical pipe, and full bottom width of box units.

- For trench installations, the sides and area over the pipe are filled with lightly compacted backfill to a minimum depth of 150 mm above the top of the pipe.
- For embankment installations, the pipe should not project more than 90% of the vertical height of the pipe above the bedding.

References in Ontario Provincial Standards:

| | |
|---------------------------|---|
| OPSS 501 | Compacting |
| OPSS 514 | Trenching, Backfilling, and Compacting |
| OPSD | Rigid Pipe Bedding, Cover, and Backfill |
| 802.030 to 802.034 | |
| OPSD | Horizontal Elliptical Rigid Pipe Bedding, Cover, and Backfill |
| 802.050 to 802.054 | |

Cover

OPSS 514 specifies that cover material be Granular A or B, Type I, II, or III, 25 mm or less in size, or native material, as specified in the Contract Documents.

- Cover material should be placed so that damage to or movement of the pipe is avoided.
- Cover material requiring compacting should be placed in layers not exceeding 200 mm in thickness, loose measurement, and compacted to 95% of the maximum dry density before a subsequent layer is placed.
- Cover material should be placed on each side of the pipe and should be completed simultaneously. At no

time should the levels on each side differ by more than the 200 mm uncompacted layer.

When single cell boxes are used in parallel for multi-cell installations, positive lateral bearing must be provided between the sides of adjacent units. This is accomplished with grout to fill the 50mm annular space.

Backfill

OPSS 514 specifies that backfill material be Granular A or B, Type I, II, or III, 25 mm or less in size, or native material, as specified in the Contract Documents.

- ❑ Backfill material should be placed in uniform layers not exceeding 300 mm in thickness for the full width of the trench and each layer should be compacted to 95% of the maximum dry density before a subsequent layer is placed.
- ❑ Backfill should be placed to a minimum depth of 900 mm above the crown of the pipe before power operated tractors or rolling equipment should be used for compacting. Uniform layers of backfill material exceeding 300 mm in thickness may be placed with the approval of the Contract Administrator.
- ❑ If the contract specifies native backfill material, acceptable earth backfill material may be substituted with the approval of the Contract Administrator. In areas within the roadway, for a depth equal to the frost treatment, the earth backfill material should

have frost susceptible characteristics similar to the adjacent material.

References in Ontario Provincial Standards:

- | | |
|-----------------|--|
| OPSS 501 | Compacting |
| OPSS 507 | Site Restoration Following Installation of Pipelines, Utilities, and Associated Structures |
| OPSS 514 | Trenching, Backfilling, and Compacting |

Handling

Proprietary lifting systems are used in Ontario for various precast concrete products, including pipe, maintenance holes, and box units. These systems offer a positive lifting connection to the pipe for added safety, and since the anchors are embedded, patching is not required.

IMPORTANT

The work procedures for material handling, worker safety, the modification of backhoes for use as cranes, and all components of any lifting assembly must comply with the Occupational Health and Safety Act requirements for Construction Projects (Ontario Regulation 213/91). A competent person designated by the contractor should inspect all lifting assemblies and attachment hardware prior to each use. Any damage or defective equipment must be immediately removed from service. All other safety procedures and recommended operating practices by the manufacturer of the lifting equipment must be followed. Failure to observe the above warnings may lead to property damage, personnel injury and death.

Load-Carrying Capacity of Lift Anchors

The MAXIMUM safe working load is clearly visible on the head of the anchor for easy recognition of the appropriate hardware and accessories for-use with the lift anchor. However the safe working load of any lift anchor may be drastically reduced due to several factors, such as:

- Length of anchor, or embedment depth
- Distance to edges, corners or openings
- Concrete compressive strength at time of initial lift
- Number of lifting points and type of rigging used
- Direction of pull (cable or sling angle)
- Impact or dynamic loads

Handling Pipe

In pipe, anchors are placed laterally along the top of the pipe. These anchors can accommodate pipe diameters from 975mm to 3600mm. Because the pipe is lifted by two points, stability during lifting is established.

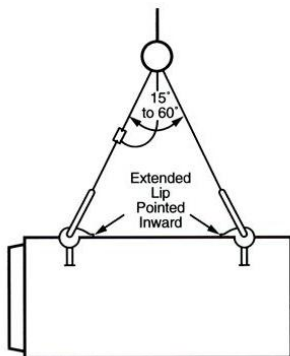

How to Use Lift Anchors for Setting Pipe

Lift anchors in concrete pipe can be used to “home” or pull the product into its final position with a special chain sling such as the P-74-S Pipe Laying Sling by Dayton Superior, shown below.

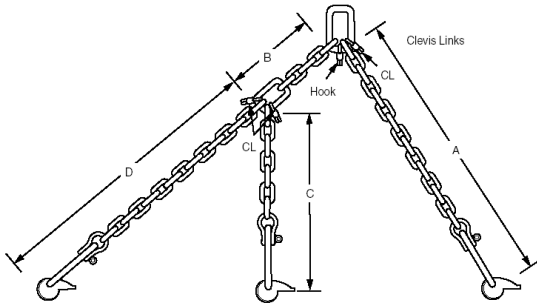

The following procedures are published in ***Guidelines for Handling Concrete Pipe and Utility Products*** by Dayton Superior, and available from the OCPA.

1. The pipe is first transported to the installation site with the symmetrical sling and lowered close to the already placed pipe.

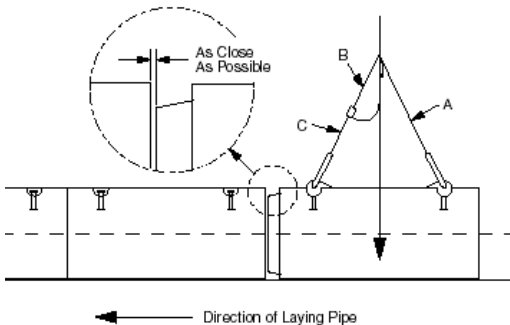

Concrete Pipe Installation

2. The long leg of the Pipe Laying Sling is attached to the farthest anchor on the previously laid pipe. The free leg is attached – out of the way – on the clevis link provided.
3. Locate the center of lift over the closest anchor of the previously laid pipe. This will properly align the direction of pull.
4. The pipe is pulled into position by slowly raising the boom on the crane or backhoe without moving the boom forward or backward.

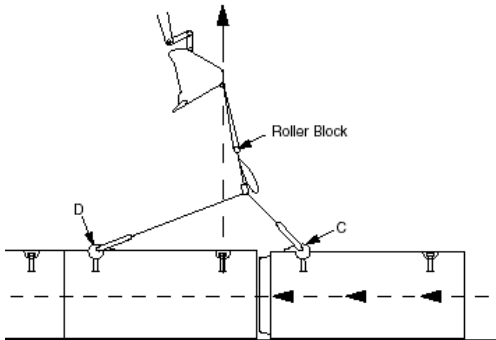

5. When the pipe has been pulled into position, the load is released and the Pipe Laying System is moved to the next pipe, and the process is repeated.

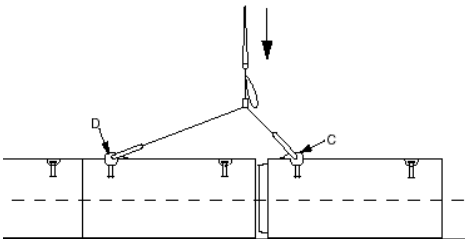

Warning: Anchors can become overloaded and fail if the crane or backhoe continues to apply load after the connection has been completed.

Jointing

Pipe should be lowered into the trench, or set in place for embankment installations, with the same care as when the pipe was unloaded from the delivery trucks.

In laying the pipe, it is general practice to face the bell end of the pipe in the upstream direction. This placing helps prevent bedding material from being forced into the bell during jointing, and enables easier coupling of pipe sections.

Jointing Materials

Several types of joints and sealant materials are utilized for concrete pipe, to satisfy a wide range of performance requirements. All of the joints are designed for ease of installation. The manufacturer's recommendations regarding jointing procedures should be closely followed to assure resistance to infiltration of groundwater and/or backfill material, and exfiltration of sewage or storm water.

The most common joint sealants and joint fillers used for sanitary sewers, storm sewers, and culverts are:

- Rubber gasket, attached or separate
- Mastic, bulk or preformed
- Mortar

Rubber Compound

Rubber gaskets are of three basic types:

- ❑ Pre-lubricated gasket for single offset joints, with one flat side, which is placed on the pipe spigot. This is the gasket type most commonly used for standard concrete gravity pipe in Ontario.
- ❑ Profile gasket for single offset joints, with one flat side, which is placed on the pipe spigot
- ❑ O-ring, which is recessed in a groove on the spigot, and confined by the bell, after the joint is completed

For all gasket types, dirt, dust, and foreign matter must be cleaned from the joint surfaces. Except for pre-lubricated type, the gasket and bell should be coated with a lubricant recommended by the manufacturer. The lubricant must be clean and be applied with a brush, cloth pad, sponge or glove. In some cases, a smooth round object, such as a screwdriver shaft, should be inserted under the gasket and run around the circumference two or three times, to equalize the stretch in the gasket, before jointing.

Rubber gaskets are required to be stored in a sheltered cool dry place. They need to be protected from prolonged exposure to sunlight, extreme heat in the summer, and extreme cold in the winter. Proper care of the gaskets prior to the installation will ensure maximum ease of installation, and maximum sealing properties.

Gaskets are generally formulated for maximum sealing performance in a standard sewer installation carrying

primarily storm water or sanitary sewage. Custom rubber formulations are available for special situations, where specific elements are being carried in the effluent. Some common examples of where a custom formulation would be required are where resistance is needed against hydrocarbons, acids, UV rays, ozone, and extreme heat.

Mastic

Mastic sealants consist of bitumen or butyl rubber and is usually cold applied. The joint surfaces must be thoroughly cleaned, dried and prepared in accordance with the manufacturer's recommendations.

Typically supplied in pre-formed coils, the flexible rope style sealant should be properly sized based on the width of the annular joint space being sealed.

During cold weather, better workability of the mastic sealant can be obtained if the mastic and joint surfaces are warmed.

Mortar

Mortar for joints is composed of one part normal Portland cement and two parts mortar sand, wetted with only sufficient water to make the mixture plastic.

The joint surface is thoroughly cleaned and soaked with water immediately before the joint is made. A layer of mortar is placed in the lower portion of the bell end of the installed pipe and on the upper portion of the spigot end of the pipe section to be installed. The spigot is then

inserted into the bell of the installed pipe until the sealant material is squeezed out. Any annular space within the pipe joint is filled with mortar, and the excess mortar on the inside of the pipe is wiped and finished to a smooth surface.

Regardless of the specific joint sealant used, each joint should be checked to be sure all pipe sections are in a homed position. For joints sealed with rubber gaskets, it is important to follow the manufacturer's installation recommendations to ensure that the gasket is properly positioned, and is under compression.

External Bands

External bands may be used in addition to any jointing material to serve two functions:

- prevent fine materials from entering the joint
- prevent infiltration of groundwater

If the prevention of bedding material from entering the conveyance system is the primary objective, filter fabric, while allowing the groundwater to infiltrate, will stop the bedding backfill material from entering.

To prevent the infiltration of water, external extruded rubber gaskets are utilized. The gasket must be of sufficient width to cover the joint, and must be installed with some tension applied, according to the manufacturer's recommendations. As the joint is

backfilled, pressure is applied to the gasket as it is pressed against the structure, providing a seal at the joint.

Jointing Procedures

Joints for pipe sizes up to 600 mm in diameter can usually be assembled by means of a bar and wood block. The axis of the pipe section to be installed should be aligned as closely as possible to the axis of the last installed pipe section, and the tongue, or spigot, end inserted slightly into the bell, or groove. A bar is then driven into the bedding and wedged against the bottom bell, or groove, end of the pipe section being installed. A wood block is placed horizontally across the end of the pipe to act as a fulcrum point, and to protect the joint end during assembly. By pushing the top of the vertical bar forward, lever action pushes the pipe into a home position.

When jointing medium diameter pipe, a chain or cable is wrapped around the barrel of the pipe behind the tongue, or spigot, and fastened with a grab hook, or other suitable connecting device. A lever assembly is anchored to the installed pipe, several sections back from the last installed section, and connected by means of a chain, or cable, to the grab hook on the pipe to be installed. By pulling the lever back, the tongue, or spigot, of the pipe being jointed is pulled into the bell, or groove, of the last installed pipe section. To maintain close control over the alignment of the pipe, a laying sling can be used to lift the pipe section slightly off the bedding foundation.

When jointing larger diameter pipe, and when granular bedding is used, mechanical pipe pullers are required. Several types of pipe pullers, or “come along” devices, have been developed, but the basic force principles are the same.

Large diameter pipe can be jointed by placing a “dead man” block inside the installed pipe, several sections back from the last installed section, which is connected by means of a chain or cable to a strong back placed across the end of the pipe section being installed. The pipe is pulled home by lever action similar to the external assembly. Mechanical details of the specific apparatus used for pipe pullers, or come along devices, may vary, but the basic lever action principle is used to develop the necessary controlled pulling force.

Note: The excavating equipment must not be used to push pipe sections together or to adjust pipe to the final grade. The force applied by such equipment can damage pipe joints.

References in Ontario Provincial Standards:

OPSS 410 Pipe Sewer Installation In Open Cut

OPSS 421 Pipe Culvert Installation In Open Cut

Summary of Jointing Procedures for Pre-lubricated Gasket for Single Offset Joints

The unique design of the pre-lubricated pipe gasket requires no field lubrication and no equalization after installation.

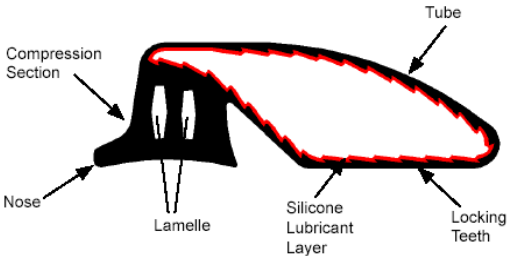

Installation:

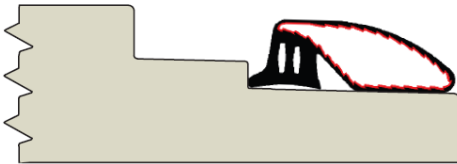

1. Ensure that bell and spigot are free from cracks, chips, or other defects.
2. Brush loose dirt, debris and foreign material from the inside surface of the bell, the spigot and the gasket.
3. Stretch gasket around the spigot, with the nose against the step, and the tube laying flat against the spigot.
4. Align the spigot with the bell, and thrust the spigot home using suitable mechanical means. The homing

Concrete Pipe Installation



process will cause the lubricated tube to “roll” over itself, above the compression section, allowing the pipe to slide forward.

Once the pipe is fully homed,

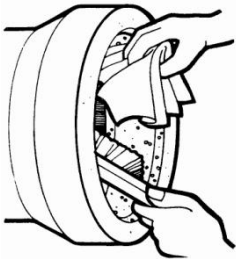
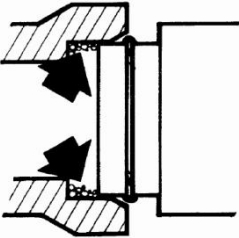

- The compression section seals the total annular space
- The rolling tube comes to rest within the small annular space – acting as a cushion against side loads
- The serrations act to resist pipe pull-out.

Source: Hamilton Kent.

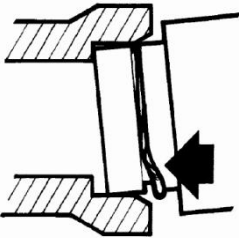
Summary of Jointing Procedures for O-Ring Gasket

| Procedure | Prevention |
|--|--|
| <p data-bbox="126 462 495 573">Clean all foreign material from the jointing surface of the bell end of the pipe.</p>  | <p data-bbox="536 462 905 573">Foreign material on the jointing surface can prevent proper homing of the pipe.</p>  |
| <p data-bbox="126 1025 495 1136">Carefully clean the spigot end of the pipe, including the gasket recess.</p>  | <p data-bbox="536 1025 905 1171">Spigot ends that are not properly cleaned may prevent proper sealing of the gasket.</p>  |

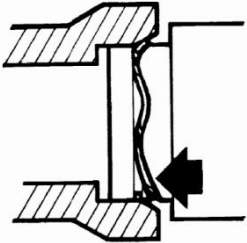
Concrete Pipe Installation

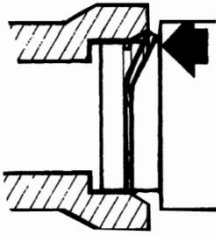
| Procedure | Prevention |
|---|--|
| <p data-bbox="127 310 477 458">Cover the entire jointing surface using an approved lubricant, using a brush, cloth, sponge or gloves.</p>  | <p data-bbox="536 310 909 458">Bells which are not properly lubricated can cause gaskets to roll, or can cause damage to the bell.</p>  |
| <p data-bbox="127 919 484 1026">Lubricate the spigot end of pipe, especially the gasket recess.</p>  | <p data-bbox="536 919 909 1026">Gaskets can twist out of the gasket recess if lacking required lubrication.</p>  |

Concrete Pipe Installation

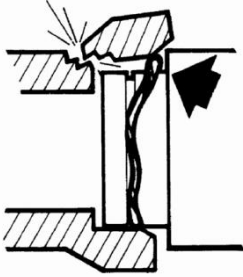
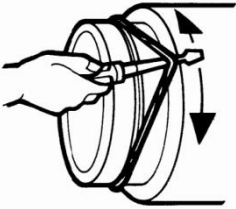
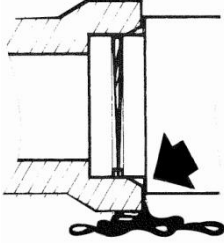
| Procedure | Prevention |
|---|--|
| <p data-bbox="129 310 461 381">Lubricate gasket before inserting it on the spigot.</p>  | <p data-bbox="536 310 896 498">Excessive force will be required to push the pipes together if lacking required lubrication. This can cause extensive damage.</p>  |
| <p data-bbox="129 931 492 1155">When fitting the gasket, equalize the gasket stretch by running a smooth round object around the circumference several times.</p>  | <p data-bbox="536 931 896 1084">Unequal stretch can cause bunching of the gasket and can damage the bell or be the source of leaks.</p>  |

Concrete Pipe Installation

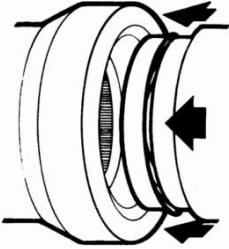
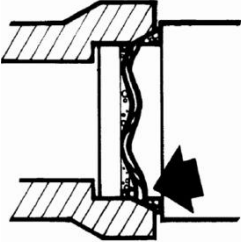
| Procedure | Prevention |
|--|---|
| <p data-bbox="128 310 456 534">When aligning the pipes, before homing the joint, check the gasket is in contact with the entry taper around the entire circumference</p>  | <p data-bbox="536 310 899 453">Improper alignment can dislodge the gasket causing leaks or possibly break the bell.</p>  |

Service Connections

Service connections to the main pipe sewer should be made using factory made tees or wyes, strap-on-saddles, or other approved saddles. Factory made tees or wyes should be used for all service connections where the diameter of the main pipe sewer is:

- Less than 450 mm, or
- Less than twice the diameter of the service connection.

Holes in the main pipe sewer should be cut with approved cutters and should be the minimum diameter required to accept the service connection. If mortar-on saddles are used, the inside of the pipe should be mortared at the connection.

Where existing service connections are to be connected to new pipe sewers or service connections, proper jointing procedures must be used.

References in Ontario Provincial Standards:

| | |
|-----------------|--|
| OPSS 410 | Pipe Sewer Installation In Open Cut |
| OPSD | Catch Basin Connection for Rigid Main Pipe Sewer |
| 708.010 | |
| OPSD | Sewer Service Connections for Rigid Main Pipe |
| 1006.010 | Sewer |

Changes in Alignment

Maintenance holes should be used when there is a need to change alignment, grade or size of a pipeline. Alignment

changes in concrete pipe sewers can also be incorporated into the line through the use of deflected straight pipe, radius pipe, or bends. Since manufacturing and installation feasibility are dependent on the particular method used to negotiate a curve, it is important to establish the method prior to excavating the trench.

- ❑ For deflected straight pipe, the joint of each pipe section is opened on one side while the other side remains in the home position. The difference between home and opened joint space is generally designated as the pull. The maximum permissible pull must be limited to that opening which will provide satisfactory joint performance. This varies for different joint configurations and is best obtained from the pipe manufacturer.
- ❑ When establishing alignment for radius pipe, the first section of radius pipe should begin one half of a radius pipe length before the beginning of curve, and the last section of radius pipe should extend one half of a radius pipe length beyond the end of curve.
- ❑ When extremely sharp curves are required, deflected straight pipe or radius pipe may not be suitable. In such cases, bends or elbows may be used.

One or more of these methods may be employed to meet the most severe alignment requirements. Since manufacturing processes and local standards vary, local concrete pipe manufacturers should be consulted to determine the geometric configurations available.

MH INSTALLATION

Structures must be installed on firm foundations at the locations and elevations specified, and must be constructed plumb and true to alignment.

Precast base slabs or monobases must be placed level before subsequent sections complete with joint seal systems be installed. Adjustment of the structure should be carried out by lifting the affected sections free of the excavation, re-leveling the base, if necessary, and re-installing the sections. Damaged sections and gaskets must be replaced.

When specified, the inside concrete bottom of the structures should be benched and channeled to accommodate the pipe installed into them. Concrete benching should have a wood float finish and the channel should have steel trowel finish. The channel must be smooth and flush with adjacent pipe inverts.

References in Ontario Provincial Standards:

| | |
|-----------------|--|
| OPSS 407 | Maintenance Hole, Catch Basin, Ditch Inlet, and Valve Chamber Installation |
| OPSD | Maintenance Hole Benching and Pipe Opening Alternatives |
| 701.021 | |

Prebenched MH Monobases

Having the precast MH base prebenched at the factory offers advantages over benching in the field. Prebenching is done under controlled conditions, resulting in a higher

quality product. When used with flexible connectors, there is no need for workers to enter the confined space created when the maintenance hole is backfilled.

Handling MH Sections

In maintenance hole products, anchors are placed on the sides of the product. Unlike pipe where there are two anchors along the top of the product, maintenance products have one or more anchors on either side of the product for stability during installation and stacking.

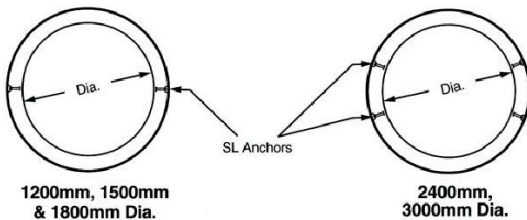

IMPORTANT

Lift anchors are sized and located specifically for each MH component to be lifted individually. Contractors must not attempt to lift more than one concrete MH component at a time, and must ensure that the load is applied to all lift anchors simultaneously in order to safely lift the product.

Review the section on Load-Carrying Capacity of Lift Anchors in this booklet.

Concrete Pipe Installation

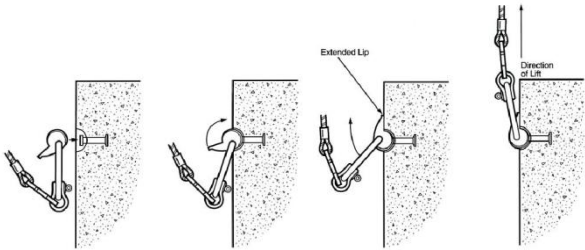

Using short lifting cables or chains that result in a sling angle greater than 60 degrees can greatly increase the possibility of damaging the top shoulders of the MH riser and potentially cause the MH riser to fail structurally. When risers have multiple hole openings, extra care must be taken to reduce the inward force from the rigging by means such as a spreader beam or longer cables.

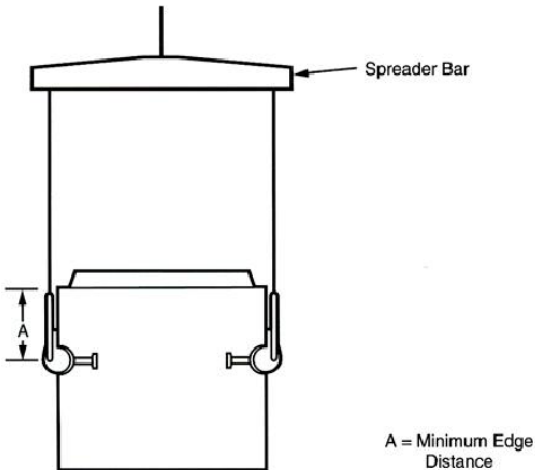

Source: Guidelines for Handling Concrete Pipe and Utility Products by Dayton Superior.

MH Connections

When the pipe connects to a rigid structure such as a maintenance hole, it may shear or crack at the connection, as a result of differential settlement. It is essential that the bedding and foundation for the connecting pipe section be highly compacted, to minimize differential settlement.

Two methods are recommended by the precast concrete pipe industry to maintain a watertight structure:

- ❑ Flexible pipe-to-MH connectors. The flexible connectors consist of a pre-formed rubber boot inserted in the MH wall opening. The pipe is inserted in the boot and the rubber connector is tightened to create a positive connection.
- ❑ Concrete grout. For many large diameter sewer applications, contractors may connect directly to MH's using grout.

OPSS 407 requires that one of the following connections be provided where a pipe connects to a structure:

- ❑ A flexible pipe joint be provided within 300 mm of the outside face of the structure for flexible and rigid pipe.
- ❑ A concrete cradle to the first joint for rigid pipe.

Concrete Pipe Installation

- ❑ A resilient connector, i.e., a flexible, watertight connector, in the structure opening for flexible and rigid pipe.
- ❑ A special approved structure designed for pipe support.

Installation of pipe connectors must be according to the manufacturer's recommendations.

All pipes, except in valve chambers, must be flush with the inside walls of the structure.

References in Ontario Provincial Standards:

| | |
|-----------------|--|
| OPSS 407 | Maintenance Hole, Catch Basin, Ditch Inlet, and Valve Chamber Installation |
| OPSS 410 | Pipe Sewer Installation In Open Cut |
| OPSD | Support For Pipe at Catch Basin or Maintenance Hole |
| 708.020 | Hole |

Precast Concrete Adjustment Units

Precast concrete adjustment units can be used to set the frame with grate or cover at the required position and elevation. OPSS 407 requires a minimum of one adjustment unit, but not more than three adjustment units at each structure.

The first adjustment unit should be laid in a full bed of mortar and aligned with the opening in the structure. Successive adjustment units are laid plumb to the first adjustment unit and should be sealed with butyl tape between each unit.

References in Ontario Provincial Standards:

| | |
|-----------------|--|
| OPSS 407 | Maintenance Hole, Catch Basin, Ditch Inlet, and Valve Chamber Installation |
| OPSD | Precast Concrete Adjustment Units for |
| 704.010 | Maintenance Holes, Catch Basins, and Valve Chambers |

Frames with Grates or Covers

When precast concrete adjustment units are used, frames with grates or covers should be set in a full bed of mortar on the adjustment units.

Ditch inlet grates should be installed as specified by the precast manufacturer, or grate supplier.

Installation of catch basin frames and grates which lie within the flow lines of a curb and gutter system should be according to OPSS 353.

References in Ontario Provincial Standards:

| | |
|-----------------|--|
| OPSS 407 | Maintenance Hole, Catch Basin, Ditch Inlet, and Valve Chamber Installation |
|-----------------|--|

BOX UNIT INSTALLATION

Precast box units should be constructed as specified in the contract. The foundation must be firm in-situ soil, or compacted backfill to provide uniform support for the full length and width of each box unit. The foundation on each side of the box unit, for a minimum distance equal to the inside width of the box unit should be at least as stable as the foundation directly below the box unit. Bedding should not be placed on frozen earth.

The maximum particle size for bedding should not exceed 25 mm in diameter, unless the bedding layer is at least 150 mm thick, in which case the maximum particle size should not exceed 40 mm in diameter.

Bedding requiring compaction should be placed in layers not exceeding 200 mm in thickness, loose measurement, and each layer should be compacted before a subsequent layer is placed. The type of equipment used must be suited to the material to be compacted, degree of compaction required, and space available.

The surface prepared to support the box units should have a 75 mm minimum thickness top leveling course of uncompacted Granular A or fine aggregates.

References in Ontario Provincial Standards:

OPSS 422 Precast Reinforced Concrete Box Culverts and Box Sewers In Open Cut

FIELD TESTING

The physical tests included in the material specifications, under which the pipe is purchased, assure that pipe delivered to the jobsite meets, or exceeds the requirements established for a particular project. The project specifications usually include acceptance test requirements to assure that reasonable quality control of workmanship and materials have been realized during the construction phase of the project. Tests applicable to all storm sewer, sanitary sewer and culvert projects are soil density, line and grade and visual inspection, often by video. For sanitary sewers, leakage limits are usually established for infiltration or exfiltration.

Soil Density

To correlate in-place soil densities with the maximum density of a particular soil, it is first necessary to determine the Optimum Moisture Content for maximum compaction, and then use this as a guide to determine the actual compaction of the fill, or backfill. Several test procedures have been developed for measuring in-place soil densities.

The maximum dry density can be determined by LS-706 or LS-623 for granulars and by LS-706, for earth. These tests can be found in the MTO Laboratory Testing Manual:

- **LS-623** - One Point Proctor Test (OPT)
- **LS-706** - Moisture - Density Relationship of Soils Using 2.5 kg Rammer and 305 mm Drop

Field density and field moisture determinations can be made in accordance with:

- **ASTM D 2922** - Standard Test Methods for Density of Soil and Soil-Aggregate in Place by Nuclear Methods (Shallow Depth); and
- **ASTM D 3017**- Standard Test Method for Water Content of Soil and Rock in Place by Nuclear Methods (Shallow Depth)

A nuclear moisture and density gauge provides a rapid, non-destructive technique for in-place determination of density suitable for control and acceptance testing of soils. It should be noted that the equipment utilizes radioactive materials, which may be hazardous to the health of users, unless proper precautions are taken.

References in Ontario Provincial Standards:

OPSS 501 Compacting

Visual/Video Inspection

Larger pipe sizes can be entered and examined, while smaller sizes must be inspected by means of closed circuit television cameras.

The following is a checklist for an overall visual inspection of a sewer or culvert project:

- debris and obstructions

Concrete Pipe Installation

- cracks exceeding the 0.3 mm wide design crack for reinforced concrete pipe
- joints properly sealed
- invert smooth and free of sags or high points
- stubs properly grouted and plugged
- laterals, diversions, and connections properly made
- catchbasins and inlets properly connected
- maintenance hole frames and grates properly installed
- surface restoration, and all other items pertinent to the construction, properly completed

References in Ontario Provincial Standards:

OPSS 409 Closed-Circuit Television Inspection Of Pipelines

Infiltration Testing

The infiltration of excessive ground water into a sanitary sewer can overload the capacity of a sewer collection system and treatment facilities. The infiltration test is intended to demonstrate the integrity of the installed materials and construction procedures as related to the infiltration of ground water. Infiltration tests should be conducted where the groundwater level at the time of testing is 600 mm or more above the crown of the pipe for the entire length of the test section. The test section is normally between adjacent maintenance holes.

- Discontinue dewatering operations at least three days before conducting the test and allow the groundwater level to stabilize.
- A watertight bulkhead is constructed at the upstream end of the test section.
- All service laterals, stubs, and fittings are plugged or capped to prevent water entering at these locations.
- A V-notch weir or other suitable measuring device is installed at the downstream end of the test section.
- Infiltrating water is allowed to build up behind the weir until the flow through the V-notch has stabilized.
- The rate of flow is then measured.

In OPSS 410, the allowable infiltration is calculated as 0.075 litres/mm diameter/100 m of pipe sewer/hour.

References in Ontario Provincial Standards:

OPSS 410 Pipe Sewer Installation In Open Cut

Exfiltration Testing

Exfiltration tests should be conducted where the groundwater level is lower than 600 mm above the crown of the pipe or the highest point of the highest service connection included in the test section.

The test section is normally between adjacent maintenance holes. The test section of the pipe sewer shall be isolated by temporarily plugging the downstream end and all incoming pipes of the upstream maintenance

hole. All service laterals, stubs, and fittings are plugged or capped to prevent water entering at these locations.

Since sanitary sewers are not designed, or expected to operate as a pressure system, care must be exercised in conducting the test and correlating the results with allowable exfiltration limits.

References in Ontario Provincial Standards:

OPSS 410 Pipe Sewer Installation In Open Cut

Testing With Water

The test section is slowly filled with water making sure that all air is removed from the line.

The test procedure outlined in OPSS 410 is as follows:

- A period of 24 hours for absorption or expansion may be allowed before starting the test, except if exfiltration requirements are met by a test carried out during the absorption period.
- Water can be added to the pipeline prior to testing until there is a head in the upstream maintenance hole of 600 mm minimum over the crown of the pipe or at least 600 mm above the existing groundwater level, whichever is greater.
- The maximum limit of the net internal head on the line is 8 m.
- In calculating net internal head, allowance for groundwater head, if any, should be made.

- The distance from the maintenance hole frame to the surface of the water should be measured.
- After allowing the water to stand for one hour, the distance from the frame to the surface of the water shall again be measured.
- The leakage should be calculated using volumes. The leakage at the end of the test period must not exceed the maximum allowable calculated for the test section.
- In OPSS 410, the allowable leakage is calculated as 0.075 litres/millimetre diameter/100 metres of pipe sewer/hour. An allowance of 3.0 litres per hour per metre of head above the invert for each maintenance hole included in the test section shall be made.
- Maintenance holes must be tested separately, if the test section fails.

Low Pressure Air Testing

Testing by use of air may be required where water is not readily available or the differential head in the test section is greater than 8 m or freezing temperatures exist.

Air control equipment that includes a shut off valve, safety valve, pressure regulating valve, pressure reduction valve and monitoring pressure gauge with pressure range from 0 to 35 kPa with minimum divisions of 0.5 kPa and accuracy of approximately 0.25 kPa must be used.

Tests are conducted between two consecutive maintenance holes.

The test procedure outlined in OPSS 410 is as follows:

- The test section shall be plugged at each end. One plug shall be equipped with an air inlet connection to fill the pipe sewer system with air.
- The test section shall be filled slowly until a constant pressure of 24 kPa is maintained. If the groundwater is above the pipe sewer being tested, the air pressure shall be increased by 3.0 kPa for each 300 mm that the groundwater level is above the invert of the pipe.
- The air pressure shall be stabilized for five minutes and then regulated to maintain it to 20.5 kPa plus the allowance for groundwater, if any.
- After the stabilization period, the time taken for a pressure loss of 3.5 kPa shall be recorded.
- The time taken for a pressure drop of 3.5 kPa shall not be less than the times shown in Table 1 of OPSS 410.
- If the length of the test section is greater than the Length for Minimum Time, the new testing time shall be a product of the length of test section multiplied by the time shown in Table 1 for the appropriate size pipe.
- If the results of an air test are marginal, the Contract Administrator may require the section to be retested using water.

Leakage Test Acceptance

- Leakage up to 25% in excess of the calculated limits may be approved in any test section provided that the excess is offset by lower leakage measurements

Concrete Pipe Installation

in adjacent sections such that the total leakage is within the allowable limits for the combined sections.

- Pipe sewers must be repaired and retested, as required, until the test results are within the limits specified in OPSS 410.
- Visible leaks must be repaired regardless of the test results.
- No part of the work will be accepted until the pipe sewers are satisfactorily tested following completion of installation of service connections and backfilling.

References in Ontario Provincial Standards:

OPSS 410 Pipe Sewer Installation In Open Cut

APPENDIX

Jacking Method of Installation

For jacked or tunneled installations, concrete pipe must be capable of withstanding the longitudinal forces encountered during installation. CSA A257.2 prescribes the following minimum requirements for concrete jacking pipe:

- minimum concrete strength of 40 MPa
- only circular reinforcing cages can be used
- inner cage reinforcement must extend into the spigot
- the length of opposite sides of any section of pipe must be within 6 mm of each other
- all other requirements for reinforced concrete pipe specified in CSA A257 must be met

In all jacking operations, the direction and jacking distance should be carefully established prior to beginning the operation. The first step of any jacking operation is the excavation of jacking pits, or construction shafts, at each end of the proposed line. The shaft from which pipe is to be jacked should be of sufficient size to provide ample working space for spoil removal, and room for the jacking head, jacks, jacking frame, reaction blocks and one or two sections of pipe. If drainage is to be discharged from the jacking shaft, a collection sump and drainage pump are necessary.

An accurate control point must be established at the bottom of the construction shaft. Provision should be made for the use of guide rails in the bottom of the shaft. For large pipe, it is desirable to set rails in a concrete slab.

Concrete Pipe Installation

Close control of horizontal and vertical alignment can be obtained by laser or transit. If excavation and pipe installation extend several hundred metres from one shaft, vertical alignment holes can be driven from the surface through which plumb lines can be dropped.

The number and capacity of jacks depend on the size and length of the pipe to be jacked, and the type of soil. The size of excavation should coincide as closely as possible to the outside dimensions, and shape of the pipe. The wall of the excavation should be approximately 25 to 50 mm larger than the pipe, and hydraulically operated jacks should have the capacity to ensure smooth and uniform advancement without over-stressing the pipe.

The excavated material is loaded into carts, or deposited onto a conveyor system, and then transported through the pipe to the jacking pit. The excavated material is then lifted from the jacking pit and deposited in a waste bank, or hauled away. Since the rate of progress of a jacking or tunneling operation is usually controlled by the rate of excavation and spoil removal, preliminary investigation and advance planning for fast and efficient removal and placement of spoil, is important in preventing delays.

Correct alignment of the pipe guide frame, jacks and backstop is necessary for uniform distribution of the axial jacking force around the periphery of the pipe. By assuring that the pipe ends are parallel and the jacking force properly distributed through the jacking frame to the pipe and parallel with the axis of the pipe, localized stress

Concrete Pipe Installation

concentrations are avoided. A jacking head is often used to transfer the pressure from the jacks, or jacking frame to the pipe.

The usual procedure in jacking concrete pipe is to equip the leading edge with a jacking head, or cutter, to protect the lead pipe by distributing the jacking pressure uniformly over the entire end bearing area of the pipe. In addition to protecting the end of the pipe, a jacking head helps keep the pipe in proper line by maintaining equal pressure around the circumference of the pipe.

As succeeding lengths of pipe are added between the lead pipe and the jacks, and the pipe is jacked forward, soil is excavated and removed through the pipe. This procedure usually results in minimum disturbance of the earth adjacent to the pipe. Use of a lubricant, such as Bentonite, to coat the outside of the pipe is helpful in reducing frictional resistance and preventing the pipe from freezing when forward movement is interrupted. Because of the tendency of soil friction to increase with time, it is usually desirable to continue jacking operations, without interruption, until completed.

The use of a cushion material such as plywood, hardboard or rubber spacers between adjacent pipe sections provide uniform load distribution throughout the entire pipe length being jacked. When pipe with rubber gasket joint sealants is being jacked, it is essential to provide cushioning between the pipe ends to avoid the

Concrete Pipe Installation

development of radial gasket pressures which may overstress the pipe sockets or grooves.

Pipe installed by jacking or tunneling may require the void between the pipe and the excavation to be filled. Sand, grout, concrete, or other suitable material should be injected into the annular space. This can be accomplished by installing special fittings into the wall of the pipe, or vertical holes drilled from the surface.

References in Ontario Provincial Standards:

OPSS 416 Pipeline and Utility Installation By Jacking and Boring

Damage Assessment

The Ontario Concrete Pipe Association and its producer membership support third party certification of their products and with that the Plant Prequalification Program (PPP) was developed to ensure precast concrete pipe and maintenance hole products leave the manufacturing facility in conformance to the program. Furthermore, the PPP engineer as well as the OCPA can provide invaluable experience in the assessment of damaged pipe.

It is important to properly assess the damage on precast concrete products and determine if it requires either a structural repair, or a non-structural, cosmetic repair. The following definitions could be used to distinguish the two:

- **Structural Repair** - A defect that meets one or more of the following criteria:
 - Main reinforcement steel is exposed
 - Damage occurs in load bearing areas
 - Embedded connection hardware is exposed
 - Cracking extends from one face through the wall to the opposite face
 - Cracks in structural elements are larger than 2.5mm in width
- **Cosmetic Repair** – A defect in the appearance of the product which does not affect its performance, and does not meet the criteria for a Structural Repair.

In CSA A257 - Standards for Concrete Pipe & Manhole Sections, precast concrete may be repaired, when

necessary, because of imperfections in manufacture or damage during handling and is acceptable if:

- The repairs are sound and properly finished and cured.
- The repaired concrete conforms to all other requirements of CSA A257.

Any repair must provide the strength and durability of the original concrete.

Joint Integrity

Pipe joints are routinely checked at the plant for dimensional accuracy and to ensure that all surfaces of the joint that comes in contact with the gasket is smooth and free of imperfections that could adversely affect the performance of the joint. The rubber gaskets are designed and tested to permit easy assembly while providing a watertight flexible seal. In spite of this attention to joint leakage prevention, leaks still can occur in the field due to handling damage or adverse installation conditions.

In CSA A257.3 - Joints for Circular Concrete Sewer and Culvert Pipe, Manhole Sections, and Fittings using Rubber Gaskets, clause 7.1 states:

Spalled areas, manufacturing imperfections, or damage (to joints) caused during handling of each pipe may be repaired and shall be considered acceptable if the repaired

pipe or manhole section conforms to the requirement of Clause 5.1.3 and provided that:

- the circumferential length of a single area to be repaired does not exceed $1/4$ the inside diameter of the pipe; or
- the combined circumferential lengths of several areas do not exceed $1/2$ the inside diameter of the pipe.

The following are a few problems typically experienced during installation and preventative measures that should be taken.

Prevention of common problems with pipe joints:

| Problem | Prevention |
|----------------------------------|--|
| Rebounding Joint Opening | <ul style="list-style-type: none">• Proper joint lubricant, if applicable• Protect gasket from extreme heat and cold• Use self-lubricating gaskets |
| Rolling or Sliding Gasket | <ul style="list-style-type: none">• Clean the joint surface and lubricate both the bell and gasket surface• No lubricant required for roll-on gaskets• Proper location of gasket on the spigot |
| Damaged | <ul style="list-style-type: none">• Maintain proper storage and handling procedures in accordance with previous sections in this guide. |

| | |
|-------------------------|---|
| Deflected Joints | <ul style="list-style-type: none">• Check line and grade settings. Good alignment results in good joint performance• Follow proper installation procedures• Prepare a stable foundation |
| Hanging Gaskets | <ul style="list-style-type: none">• Stable foundation• Proper construction of bedding under barrel of pipe• Proper compaction under maintenance holes |

Cracks

Reinforced concrete pipe is designed to permit cracking. The design crack, 0.3mm in width over a length of not less than 300mm is the measure used. Not understanding this process, cracking of reinforced concrete pipe can present a concern to infrastructure owners.

Cracks in reinforced concrete pipe are generally discovered through video surveys or visual assessments done as a requirement of the contract. Timing of such inspection is typically prior to the assumption of an installed system by the owner. It is very important that owners undertake these types of inspections to elevate the accountability of all those involved in the satisfaction of the contract. There can be no denying that proper installation and inspection will have a tremendous impact on the satisfaction of the expected service life of new system. In order for owners to achieve a final project with

the goals of economic and adequate serviceability, proper assessment must be stressed. Issues, which may arise in the evaluation of cracks include:

- Width
- Length
- Orientation
- Location
- Severity

This section will address each of these issues.

Width

The design (service) crack used in reinforced concrete pipe is the 0.3mm crack over a length of at least 300mm. This crack will generally appear at the invert, and occasionally the obvert, of the reinforced concrete pipe as the highest tensile stress incurred by the pipe loads occurs at these locations. The design crack is V-shaped in nature and is widest at the surface penetrating usually no further than the first reinforcing cage in the pipe. It is very difficult to determine the magnitude or significance of a crack and the unavoidable magnification of the crack in the pipe that is inherent with video inspection technology today. As a result it is critical that analysis of sewer video be done by trained personnel.

Hairline cracks are extremely fine cracks, narrower than design cracks yet can be visible during video inspections. Hairline cracks are often mistaken as design cracks, yet the

hairline crack is in fact the prelude to the appearance of the design crack, which will generally not occur.

Shrinkage cracks can occur during the curing process of reinforced concrete pipe. As concrete cures, moisture disappears from the concrete matrix. Depending on the rate of curing, shrinkage cracks can occur, i.e. the more rapid the curing, the greater likelihood of shrinkage cracks. Shrinkage cracks are generally hairline type cracks appearing circumferentially on the outer surface of the pipe barrel and quite often do not penetrate into the pipe wall.

The width of a crack is a critical consideration when determining the impact on the durability and or structural integrity of an installed reinforced concrete pipe.

The following criteria can be used as a guide:

- A crack width in excess of 0.3mm, but not greater than 2.5mm should be pressure injection grouted.
- Any crack less than 0.3mm typically cannot be injected adequately, so the routing procedure should be followed.
- The Portland Cement Association considers a crack less than 0.1mm to be watertight, therefore should not need to be repaired. The routing procedure may be considered for cosmetic reasons.

Length

The length of a crack is rarely an indication of poor quality material or improper installation practices. In most if not all conditions where a crack is evident in a pipe, the width and location of the crack is more critical to understand and evaluate.

Orientation

Longitudinal cracks run lengthwise along the barrel of the pipe and can be single cracks or in some instances of severe damage can become multi-directional in appearance. Circumferential cracks run around the barrel of the pipe and may or may not propagate the full inner circumference of the pipe barrel.

Location

Understanding how pipe performs in the installed condition is critical when evaluating the location of a crack.

Longitudinal cracks visible at the invert or obvert of the pipe are indications the pipe has exceeded the load to which it was designed.

Longitudinal cracking at any other location along the inside barrel of the pipe can generally be attributed to poor construction practices which may include but are not limited to improper handling or weak installation and backfilling techniques. Pipe installations in certain rock formations, particularly shales and shaly limestones, exhibit a tendency to expand and may result in “rock

squeeze”. In parts of Southern Ontario, an overwhelming amount of evidence has been accumulated over the years on the detrimental effect of rock squeeze on underground structures.

Multi-directional longitudinal cracking, an indication the pipe has been subjected to some sort of impact load, can most certainly be attributed to the lack of care taken when installing or handling the pipe. This evidence should be considered carefully when assessing the integrity and future performance of the installed pipe.

Circumferential cracks are in no way attributed to the installation conditions to which the pipe was designed to handle. In fact, cracks propagating circumferentially on the inner surface of the pipe can be attributed in most cases to differential settlements in the pipe bedding. This condition can result from uneven placement and over-compaction of the bedding material creating point loads along the barrel of the pipe. Furthermore, failure to dig ‘bell holes’ to accept a protruding pipe bell, a feature of many small to mid range diameter pipe, can lead to the development of circumferential cracking at or just beyond the pipe joint.

Severity

The key to determining if structural concerns exist is the degree or severity of the damage to the pipe. Hairline and design cracks are not a result of damage to the pipe and therefore needn’t be considered for repair. Otherwise, longitudinal and circumferential cracking is an indication of

damage to which the severity must be assessed. As discussed later, autogenous healing is a powerful process in the repair of minor damage sustained by a concrete pipe. In most if not all cases where autogenous healing has sealed the defect, the integrity of the pipe should be considered sound. Pipe cracking or damage beyond the scope of autogenous healing must be evaluated further.

Cracks where concrete has been displaced must be considered for a structural type of repair. Also of concern would be a crack or defect that is allowing water to infiltrate into the pipe system. The infiltration can be relatively clear or it can be a 'rust-like' colour. The latter is an indication the steel in the pipe is being impacted by water. Regardless, both situations require remediation, the extent of which must be assessed on the amount of the infiltration and structural damage.

Basis of Acceptance

The final acceptance of the rehabilitation of reinforced concrete pipe should be subject to visual or video inspection. This is the only way to ensure the ultimate owner of the system has assurance that the pipeline will be durable and achieve its intended service life. During the evaluation process of video inspection, the owner must be aware of what the video is actually showing. Distortion can occur due to the presence of water or to magnification of the video. To properly evaluate the extent of a crack, actual measurements must take place. If this is not possible due to the size of the pipe, the owner should rely on professional judgment. The practitioner

should look for the visible signs of structural damage. If the crack appears wide, and the pipe is displaced on either side of the crack, or the location of the crack is not conducive with the design crack, concern is justified. If no displacement is apparent, the process of Autogenous Healing will, in all likelihood, seal the crack and ensure the longevity of the reinforced concrete pipe can be achieved.

Autogenous Healing

This phenomenon occurs between opposing surfaces of narrow cracks. The mechanism of the healing is the hard white 'crust like' formation on the concrete pipe known as calcium carbonate. The crack healing requires the presence of moisture, which when reacting with cement powder, restarts the hydration (curing) process.

The strength of the healed crack has been studied under laboratory conditions. It has been suggested that full healing creates a monolithic structure, so the pipe is "as good as new", and should be considered structurally sound and capable of performing in the manner originally intended.

Regardless of the mechanism, autogenous healing will occur in concrete pipe that has cracked. Some literature has reported cracks as wide as 1.5mm healed in a period of 5 years and cracks of 0.2mm healed completely within 7 weeks. It appears that the narrower the crack, the more rapid the healing can occur. The Ohio DOT Supplemental Specification 802 - Post Construction Inspection of Storm Sewers and Drainage Structures identifies the rehabilitation methods for installed pipe which has evidence of cracking. The specification requires the contractor to "Do Nothing" for cracks up to 1.8mm in width, with the expectation that autogenous healing will create a watertight pipe over a period of a few years.

Rehabilitation Techniques

The National Association of Sewer Service Companies (NASSCO) maintains invaluable information on the installation and rehabilitation of pipelines and manholes as provided by its members. The NASSCO Specification Guidelines are intended to assist engineers and municipal officials to properly specify sewer rehabilitation work and include the following topics:

- CCTV/Inspection
- Cleaning
- Coatings
- Centrifugally Cast Concrete Pipe (CCCP)
- Cured-In-Place-Pipe (CIPP Mainline Pipes)
- Fold and Form/Folded and Reformed
- Grouting/Joint Sealing
- Lateral/Renewal Repair
- Manhole
- Pipebursting
- Point Repair/Spot Repair
- Pumping
- Roll Down/Diameter Reduction
- Root Control
- Testing

Open communication between the owner and the concrete pipe industry may draw on many years of experience and lead to accurate assessments of installed infrastructure and the implementation of the appropriate

remedial action necessary to ensure damaged pipe satisfies project design life criteria.

Chemical Grout

The American Society for Testing and Materials (ASTM) specifications can provide information on the rehabilitation of sewers and maintenance holes using chemical grouting. Chemical grouting is used to stop infiltration of ground water and exfiltration of sewage in gravity flow sewer systems that are structurally sound.

ASTM F2304 - *Standard Practice for Rehabilitation of Sewers Using Chemical Grouting* describes the procedures for testing and sealing individual sewer pipe joints with appropriate chemical grouts using the packer method. This practice applies to sewers 150 to 1050 mm in diameter. Larger diameter pipe may be grouted with specialized packers or man entry methods. This practice should not be used for longitudinally cracked pipe, severely corroded pipe, structurally unsound pipe, flattened, or out-of-round pipe.

ASTM F2414 - *Standard Practice for Sealing Sewer Manholes Using Chemical Grouting* covers proposed selection of materials, installation techniques, and inspection required for sealing manholes using chemical grout. Manholes to be grouted are of brick, block, cast-in-place concrete, precast concrete, or fiberglass construction.

ASTM F2454 - *Standard Practice for Sealing Lateral Connections and lines from the mainline Sewer Systems by the Lateral Packer Method, Using Chemical Grouting* covers the procedures for testing and sealing sewer lateral connections and lateral lines from the mainline sewer with appropriate chemical grouts using the lateral packer method. This practice applies to mainline sewer diameters of 150 to 600 mm with 100, 125 or 150 mm diameter laterals. Larger diameter pipes with lateral connections and lines can be grouted with special packers or man-entry methods. The mainline and lateral pipes must be structurally adequate to create an effective seal.

Knowledge of chemical additives can increase the performance of a chemical grout for varying conditions. Additives can:

- Increase strength
- Reduce shrinkage
- Increase viscosity
- Assist in the filling of large voids
- Inhibit root growth
- Resist low temperatures

Trenchless Technologies

Trenchless technology includes a large family of methods utilized for installing and rehabilitating underground utility systems with minimal surface disruption and destruction resulting from excavation. The Centre for Advancement of Trenchless Technologies (CATT) was established in 1994 to help municipalities address their buried infrastructure

challenges with specific reference to trenchless technologies. CATT is a grouping of university, municipal, industrial, business and government agencies committed to the advancement of knowledge, materials, methods and equipment used in trenchless technologies.

CATT's Technical committee has developed several trenchless technology specifications have been adopted and published as Ontario Provincial Standards.

References in Ontario Provincial Standards:

| | |
|-----------------|--|
| OPSS 409 | Closed-Circuit Television Inspection of Pipelines |
| OPSS 415 | Pipeline and Utility Installation by Tunneling |
| OPSS 416 | Pipeline and Utility Installation by Jacking and Boring |
| OPSS 450 | Pipeline and Utility Installation in Soil by Horizontal Directional Drilling |
| OPSS 460 | Pipeline Rehabilitation by Cured-In-Place Pipe |
| OPSS 463 | Pipeline and Conduit Installation by Pipe Bursting |

References

1. **Ontario Concrete Pipe Association (OCPA)**
www.ocpa.com
 - Concrete Pipe Design Manual
2. **Ontario Provincial Standards for Roads and Public Works (OPS)**
www.ops.on.ca
 - Specifications (OPSS)
 - Drawings (OPSD)
3. **Canadian Standards Association**
www.csa.ca
 - A257 Series – Standards for Concrete Pipe and Manhole Sections
 - A23.1 – Concrete Materials and Methods of Concrete Construction
 - CAN/CSA S6 – Canadian Highway Bridge Design Code
4. **Infrastructure Health and Safety Association (IHSA)**
www.ihsa.ca
 - Occupational Health and Safety Act
 - Ontario Regulation 213/91 for Construction Projects (Amended to O. Reg. 443/09)
5. **Ontario Building Code (OBC)**
www.obc.mah.gov.on.ca
6. **Dayton Superior Corporation**
www.daytonsuperior.com
 - Guidelines for Handling Concrete Pipe and Utility Products

7. **American Concrete Pipe Association (ACPA)**
www.concrete-pipe.org
 - Concrete Pipe Design Manual
 - Concrete Pipe Installation Guide
 - Design Data
8. **American Society for Testing and Materials (ASTM)**
www.astm.org
9. **National Association of Sewer Service Companies (NASSCO)**
www.nassco.org
 - Specification Guidelines
10. **Centre for Advancement of Trenchless Technologies (CATT)**
www.civil.uwaterloo.ca/catt/



**447 Frederick Street, Suite 200
Kitchener, ON N2H 2P4**

1-800-435-0116

www.ocpa.com